

# RAM

## INDUSTRIE

中遠國際有限公司

氣度  
源自非凡的姿態

義式原裝進口伸縮餐桌

MADE

TAY



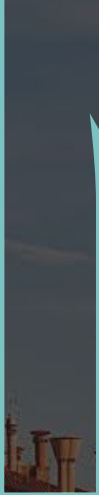

## ▶ 目錄

### 義式原裝風情伸縮餐桌

Angelica----- 01

Adele----- 02

Adriana----- 03

Alessia----- 04

Amanda----- 05

Agnese----- 06

### 專業滑軌

Serie 46-----08

Serie 42-----09

Serie 41-----10

Serie 58-----11

Serie G42---- 12

Serie 43450-- 13

# RAM INDUSTRIE

中遠國際有限公司

設立於2002年代理義大利 RAM INDUSTRIE SRL (www.ramindustrie.it) 為世界級亞太滑軌採購中心。  
RAM (TAIPEI)符合國際化及全球化合作進出口貿易標準，且擁有完整的亞太區供應鏈及運輸。

我們以維持歐洲產品品質及協調亞洲各廠商合作生產為宗旨，為客戶打造完善的標準化、客製化以及安全庫存化。以專業服務為出發的精神，秉持著國際化以客為尊的理念，結合多年專業銷售經驗與創新設計視野，配合義大利RAM進攻全歐洲市場，使其成為家喻戶曉的品牌，並贏得歐洲最專業滑軌供應商的美名。供應全球65個國家的客戶在享受高品質產品的同時又同時享有全球化的專業服務。

自2016年開始，義大利 RAM INDUSTRIE 投入製造義式家居，迎合目前小空間家居趨勢，結合米蘭時尚家居設計風格打造高功能性家具；全系列家具產品採用高規格E1環保板材，共創環保風氣而不使用原木材質，攜手維護地球資源，結合RAM品牌滑軌延伸出的TAVOLO功能性伸展餐桌，於2017年誕生TAVOLO系列餐桌簡約、實用、時尚、經濟、無毒、安心，體驗歐洲式的生活品味與家居裝飾，打造歐風簡約的時尚生活。

RAM 品牌的鋼珠滑軌更是與國內知名廠商合作的優質產品，“MADE IN TAIWAN”更以專業品牌形象讓您使用更滑順、更安靜、更安心！RoHs無毒電鍍符合歐盟檢驗標準、美國BIFMA檢驗標準，以專業且高品質的五金滑軌打造更完美的抽屜使用體驗！輕鬆創造安靜、優雅及舒適的使用空間！

品質保證是我們的榮譽 Quality guarantee is our Reputation  
快樂服務是我們的態度 Good service is our Attitude  
專業技術是我們的經營 Professional is our Management



Tool and Tech Co., Ltd. was founded in 2002 to help RAM in purchasing in Asia-Pacific.  
RAM (Taipei) meets international and global trade policies and has complete supplier chain and transportation in Asia-Pacific. Our faith is to maintain European Quality and to coordinate with suppliers in Asia-Pacific, to have standardize, customize, and also good management in Stock.

We are kind and professional. We take "Service" as our faith. Combine with sales experiences for several years and innovation view to help with RAM, it becomes more and more famous and gains the good reputation as the best professional ball bearing slide supplier in Italy.

RAM provides not only high quality products but also good services to more than 65 countries in the world.  
Since 2016, RAM Industrie starts to engage in Italian furniture. Cater to the market and combine Milan's fashion design, RAM start to produce functional furniture.

Series furniture use high standard E1 board instead of solid wood as the material to show our awareness on protecting the environment.

With RAM aluminum slide, RAM has its first extension table series "TAVOLO" in 2017.

Series TAVOLO is non-toxic, environmental-friendly, practical and fashionable in modern style.

RAM ball bearing slide is made in Taiwan with well-known brand. Non-toxic plating meets EU regulation ROHS and the United States BIFMA standard.

The professional makes it smooth, quiet, and make people feel at ease when using. You can enjoy high quality life with good deal RAM slides.

TAVOLO   
CONSOLLE.IT  
 MADE IN ITALY

## 義式原裝伸縮餐桌

源自義大利家居的堅持與保證  
獻給擁有非凡氣度且熱愛空間的你

對極致的空間運用追求，是現代家居設計的主要目標；TAVOLO 系列以米蘭時尚家居風格結合特殊的鋁合金滑軌，打造出優質的高功能性家具，迎合目前小空間家居趨勢。穩固且滑順的鋁合金滑軌，TAVOLO 對家具純正的工藝，讓玄關擺飾桌輕鬆變成12人座的大餐桌，即刻體驗濃厚的歐洲生活品味與家居裝飾，與家人朋友共享歐風簡約的時尚生活。

## ANGELICA 艾卓莉卡

精緻的倫巴底圓角風格及專用的收納空間，  
典雅的生活品味細細展現，安全的桌角  
給予家人舒適安心的居家生活空間。

Round edge shows our concerning about safety.  
With perfect storage of the boards, Angelica  
gives you comfortable but elegant life style.



商品系列：艾卓莉卡Angelica  
原廠型號：91C0146  
材 料：E1塑合板  
五 金：鋁合金伸縮滑軌  
載 重：60 KG  
顏 色：  
桌體尺寸：開 - 長300公分X寬90公分  
圖 - 長50公分X寬90公分

Collection : Angelica  
Item No. : 91C0146  
Material : E1 Partical Board  
Componet : Alum Slide  
Limited Weight : 60 KG  
Color :   
Table Size : Open : L300xW90cm  
Close : L 50xW90cm



## ADELE 艾黛兒

艾黛兒的圓，代表著我們對生活中大小事的期望，我們渴望圓滿的生活。

The shape of Adele like our expectation of life. We expect everything happen in our life could be perfect just like a round.



商品系列：艾黛兒Adele  
原廠型號：91C0155  
材 料：E1塑合板  
五 金：鋁合金伸縮滑軌  
載 重：60 KG  
顏 色：  
桌體尺寸：開 - 長215公分X寬90公分  
                  關 - 長50公分X寬90公分

Collection : Adele  
Item No. : 91C0155  
Material : E1Partical Board  
Componet : Alum Slide  
Limited Weight : 60 KG  
Color :   
Table Size : Open - L215xW90cm  
                  Close - L50xW90cm

## ADRIANA 艾德里安娜

方正的邊角，極簡約的歐式邊桌  
風格和樸實的外型融合生活，驚喜的  
伸展功能，應付任何歡聚場合。

The square shape of Adriana and  
the pure white represent  
our attitude in life.

商品系列：艾德里安娜Adriana  
原廠型號：91C0125  
材 料：E1 塑合板  
五 金：鋁合金伸縮滑軌  
載 重：60 KG  
顏 色：  
桌體尺寸：開 - 長300公分X寬90公分  
關 - 長50公分X寬90公分

Collection : Adriana  
Item No. : 91C0125  
Material : E1 Partical Board  
Componet : Alum Slide  
Limited Weight : 60 KG  
Color :   
Table Size : Open: L300xW90cm  
Close: L50xW90cm







## ALESSIA 愛麗絲

特別的邊角設計，意味著  
生活中的平順與困頓，  
愛麗絲的美與智慧，將會克服所有。

The Special corner design of  
Alessia means the hard  
times and the good times in life.  
With beauty and intelligence,  
Alessia will conquer all.

商品系列：愛麗絲Alessia  
原廠型號：91C0105  
材 料：E1 塑合板  
五 金：鋁合金伸縮滑軌  
載 重：60 KG  
顏 色：  
桌體尺寸：開 - 長300公分X寬90公分  
闔 - 長50公分X寬90公分

Collection : Alessia  
Item No. : 91C0105  
Material : E1 Partical Board  
Componet : Alum Slide  
Limited Weight : 60 KG  
Color :   
Table Size : Open : L300xW90cm  
Close : L50xW90cm



## AMANDA 艾曼達

圓滑的邊角、正直的桌邊設計，簡約的風格給有設計感的您，創新工藝結合米蘭時尚元素，打造出實用簡約的義式風情。

Round corner with straight table side, we design the simply modern style to you. Combine with innovative technique and Milan fashion, Amanda leads you to live in Italian modern style.

商品系列：艾曼達Amanda  
原廠型號：91C0135  
材 料：E1塑合板  
五 金：鋁合金伸縮滑軌  
載 重：60 KG  
顏 色：  
桌體尺寸：開 - 長300公分X寬90公分  
                  關 - 長50公分X寬90公分

Collection : Amanda  
Item No. : 91C0135  
Material : E1 Partical Board  
Componet : Alum Slide  
Limited Weight : 60 KG  
Color :   
Table Size : Open: L300xW90cm  
                  Close: L 50xW90cm





## AGNESE 艾格尼斯

羅馬風情的幾何收邊，外表看似方正簡單卻大有內涵，特別的收納空間在歡聚同時，享受功能性家居帶來的時尚便利。

Square edge design with storage feature, you can enjoy the modern convenience from Agnese.

商品系列：艾格尼斯Agnese

原廠型號：91C0115

材 料：E1 塑合板

五 金：鋁合金伸縮滑軌

載 重：60 KG

顏 色：

桌體尺寸：開 - 長300公分X寬90公分

關 - 長50公分X寬90公分

Collection : Agnese

Item No. : 91C0115

Material : E1 Partical Board

Componet : Alum Slide

Limited Weight : 60 KG

Color :

Table Size : Open - L300xW90cm

Close: L50xW90cm



**RAM**  
INDUSTRIE



專業滑軌  
DRAWER  
SLIDES

# Serie 46

標準全展開三節滑軌  
(大板)

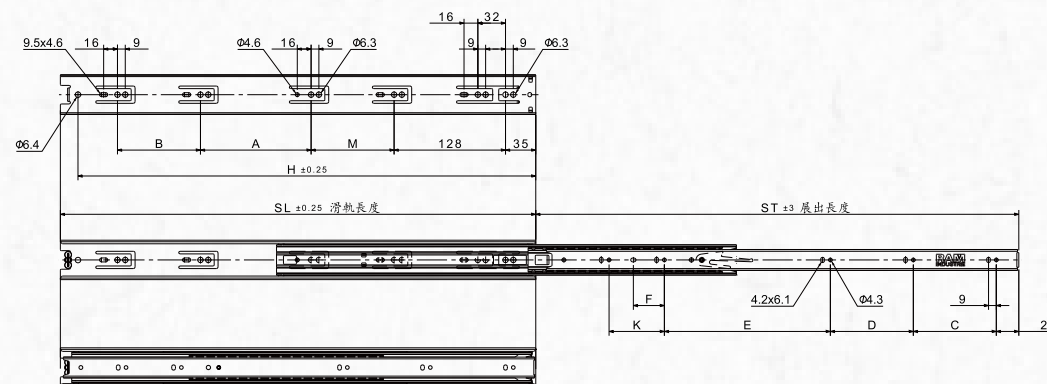

- 滑軌耐用·行程平穩順暢
- 正確安裝及使用狀況下壽命達50,000次
- 高品質平邊防跳珠設計
- 壓開式把手快拆機構·拆卸簡易快速

- Stable, running smooth and silence
- 45kgs (100lb) loading by cycle testing 50,000 times
- Quick release handle

材質：冷軋鋼板/厚度 1.2x1.2x1.5mm  
 閉合長度：250mm ~ 700mm  
 展開型式：三節全展型  
 施工間隙：單邊12.7mm (+0.2mm -0mm)  
 滑軌高度：45.7mm  
 最大載重：一組45公斤(100磅)  
 快拆系統：壓開式把手快拆  
 表面處理：鍍鋅  
 適用產品：家具櫥櫃與一般抽屜  
 包裝方式：套裝15組/箱

Material: SPCC / T=1.2x1.2x1.5mm  
 Length: 250mm ~ 700mm (10"~28")  
 Extension: Full Extension  
 Side Clearance: 12.7mm (+0.2mm -0mm)  
 Height: 45.7mm (1-13/16")  
 Loading rate: 45kgs (100lb)  
 Finishing: Zinc plating  
 application : wood furniture, cabinet  
 Packing: 15 pairs/carton

產品編號 CODE.	滑軌長度 SL	展出長度 ST	A	B	C	D	E	F	K	H	M
46250	250	254	-	-	96	-	-	-	-	-	-
46300	300	304.8	-	-	96	128	-	-	-	-	96
46350	350	355.6	-	-	96	160	-	-	-	-	96
46400	400	406.4	96	-	96	96	128	-	-	-	96
46450	450	457.2	128	-	96	96	160	-	-	-	96
46500	500	508	128	64	128	192	96	-	-	-	96
46550	550	558.8	128	96	96	96	192	-	64	515	96
46600	600	609.6	128	128	96	96	192	-	96	-	96
46650	650	660.4	128	192	96	96	192	-	160	-	96
46700	700	711.2	128	192	224	192	128	96	-	-	96
46800	800	811	192	192	224	128	192	-	160	-	160

單位：mm

# Serie 42

全展開油壓三節緩衝  
回歸滑軌 (大板)

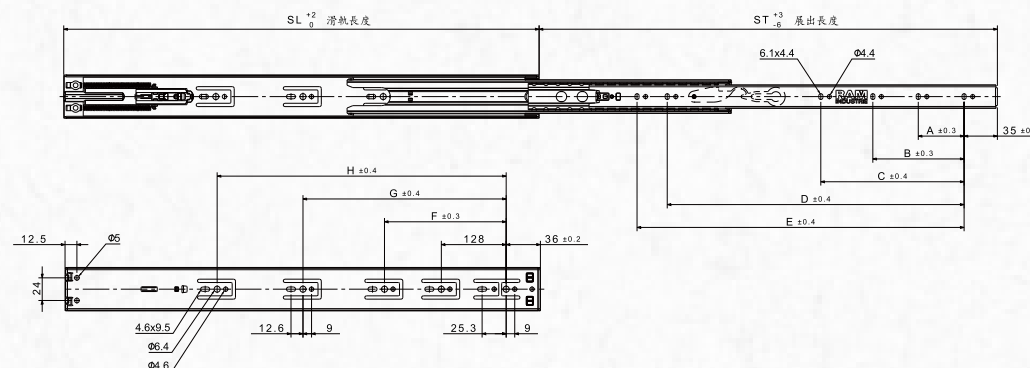
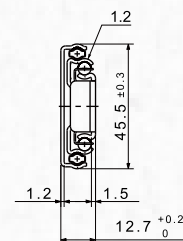

- 滑軌耐用 · 行程平穩順暢
- 正確安裝及使用狀況下壽命達50,000次
- 高穩定性靜音緩衝回歸機構
- 專利防脫鉤及防跳珠設計
- 前拉式內軌快拆機構 · 拆卸簡易快速

- Stable and running smooth with soft closing device
- 45kgs (100lb) loading by cycle testing 50,000 times
- High quality oil piston with double spring
- Quick release handle with damping device

材質：冷軋鋼板/厚度 1.2x1.2x1.5mm  
 閉合長度：300mm ~ 700mm  
 展開型式：三節全展型  
 施工間隙：單邊12.8mm (+0.2mm -0mm)  
 滑軌高度：45.5mm  
 最大載重：一組45公斤(100磅)  
 快拆系統：前拉式專利快拆  
 表面處理：亮白鍍鋅 (鍍黑鋅)  
 適用產品：家具櫥櫃與一般抽屜  
 包裝方式：套裝10組/箱

Material: SPCC / T=1.2x1.2x1.5mm  
 Length: 250mm ~ 700mm (10"~28")  
 Extension: Full Extension  
 Side Clearance: 12.7mm (+0.8mm -0mm)  
 Height: 45.5mm (1-13/16")  
 Loading rate: 45kgs (100lb)  
 Finishing: Bright Zinc plating (Black option)  
 application : wood furniture, cabinet  
 Packing: 10 pairs/carton

產品編號 CODE.	滑軌長度 SL	展出長度 ST	A	B	C	D	E	F	G	H
42300	300	238	-	-	-	-	156	-	-	-
42350	350	305	-	-	-	-	200	-	-	-
42400	400	378	96	-	-	-	256	208	-	-
42450	450	430	128	-	-	-	294	256	-	-
42500	500	482	96	160	-	-	344	304	-	-
42550	550	533	96	160	352	-	394	224	352	-
42600	600	584	128	192	384	-	444	224	352	-
42650	650	635	128	224	416	-	494	224	352	448
42700	700	685	128	224	416	480	544	224	352	496

單位：mm

# Serie 41

全展開按彈三節滑軌  
(大板)

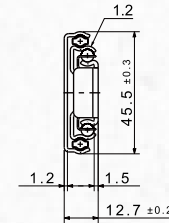

- 滑軌耐用 · 行程平穩順暢
- 正確安裝及使用狀況下壽命達50,000次
- 按壓彈出機構(拍拍手)及全段避震設計
- 專利防脫鉤及防跳珠設計
- 前拉式內軌快拆機構 · 拆卸簡易快速

- Stable and running smooth
- 45kgs (100lb) loading by cycle testing 50,000 times
- Push-open (REBOUND) device with full extension
- Quick release handle with damping device

材質：冷軋鋼板/厚度 1.2x1.2x1.5mm  
 閉合長度：250mm ~ 700mm  
 展開型式：三節全展型  
 施工間隙：單邊12.7mm (+0.8mm -0mm)  
 滑軌高度：45.5mm  
 最大載重：一組45公斤(100磅)  
 快拆系統：前拉式專利快拆  
 表面處理：亮白鍍鋅 (鍍黑鋅)  
 適用產品：家具櫥櫃與一般抽屜  
 包裝方式：套裝10組/箱  
 抽頭間隙：按彈預留 2mm ~ 3mm

Material: SPCC / T=1.2x1.2x1.5mm  
 Length: 250mm ~ 700mm (10"~28")  
 Extension: Full Extension  
 Side Clearance: 12.7mm (+0.8mm -0mm)  
 Height: 45.5mm (1-13/16")  
 Loading rate: 45kgs (100lb)  
 Finishing: Bright Zinc plating (Black option)  
 application : wood furniture, cabinet  
 Packing: 10 pairs/carton  
 Drawer front mounted clearance: 2mm~3mm

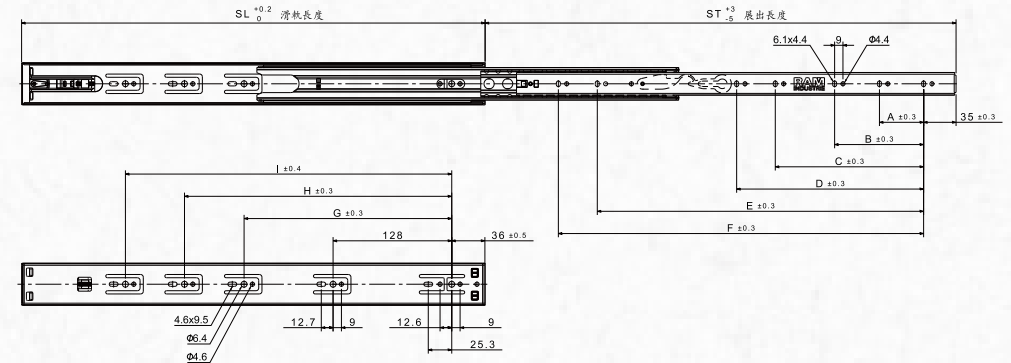

產品編號 CODE.	滑動長度 SL	展出長度 ST	A	B	C	D	E	F	G	H	I
41250	250	238	-	-	-	-	-	156	-	-	-
41300	300	305	-	-	-	-	-	200	-	-	-
41350	350	356	96	-	-	-	-	256	192	-	-
41400	400	406	128	-	-	-	-	294	224	-	-
41450	450	457	96	160	-	-	-	344	288	-	-
41500	500	508	96	160	352	-	-	394	224	352	-
41550	550	559	128	192	384	-	-	444	224	352	-
41600	600	610	128	224	416	-	-	494	224	352	448
41650	650	660	128	224	416	480	-	544	224	352	480
41700	700	711	128	224	288	480	544	594	224	352	544

單位：mm

# Serie 58

荷重型90公斤全展三節  
鋼珠滑軌

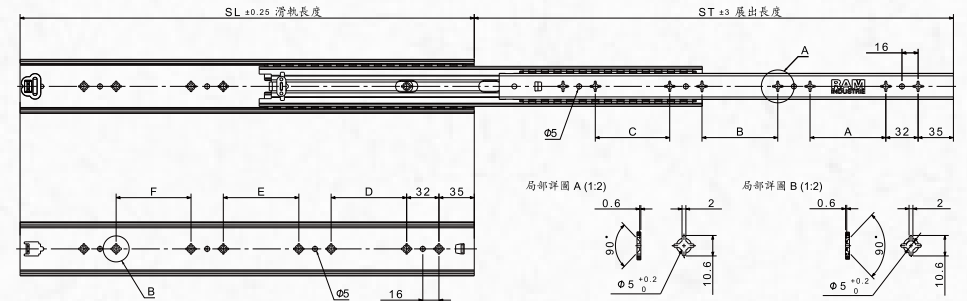
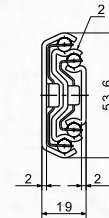

- 荷重型鋼珠滑軌 · 行程平穩順暢
- 正確安裝及使用狀況下壽命達50,000次
- 高剛性板厚2mm · 90公斤荷重
- 兩段自鎖阻尼橡皮及全鐵製珠座設計
- 32mm標準孔位 · 直徑5.1mm梅花沉頭孔

- Stable, running smooth and silence
- 90kgs (200lb) loading by cycle testing 50,000 times
- Heavy duty standard full extension ball bearing slide
- Full extension length up to 1000mm (customization welcome)

材質：冷軋鋼板/厚度 2x2x2mm  
 閉合長度：300mm ~ 1000mm  
 展開型式：三節全展型  
 施工間隙：單邊19mm (+0.5mm -0mm)  
 滑軌高度：53.6mm  
 最大載重：一組90公斤(200磅)  
 快拆系統：重型滑軌不可拆  
 表面處理：亮白鋅  
 適用產品：工具櫃及荷重抽屜  
 包裝方式：套裝8組/箱

Material: SPCC / T=2x2x2mm  
 Length: 300mm ~ 1000mm (10"~40")  
 Extension: Full Extension  
 Side Clearance: 19mm (+0.5mm -0mm)  
 Height: 53.6mm (2-1/16")  
 Loading rate: 90kgs (200lb)  
 Finishing: Bright Zinc plating  
 application : Heavy duty drawer, Tool box,  
 Industry application  
 Packing: 8 pairs/carton

產品編號 CODE.	滑軌長度 SL	展出長度 ST	A	B	C	D	E	F
58300	300.25	328	128	-	-	128	-	-
58350	350.25	377	192	-	-	192	-	-
58400	400.25	426	96	96	-	96	96	-
58450	450.25	475	128	128	-	128	128	-
58500	500.25	525	160	128	-	160	128	-
58550	550.25	574	160	192	-	160	192	-
58600	600.25	623	224	192	-	224	192	-
58650	650.25	672	224	224	-	224	224	-
58700	700.25	721	256	256	-	256	256	-
58750	750.25	771	192	192	-	256	192	128
58800	800.25	820	192	192	192	192	192	192
58850	850.25	869	224	224	160	192	224	168
58900	900.25	918	224	224	224	224	224	224
58950	950.25	967	224	288	224	224	288	224
581000	1000.25	1017	224	288	256	224	288	256

單位：mm



# Serie G42

全展開銅管油壓三節緩衝  
回歸滑軌 (大板)

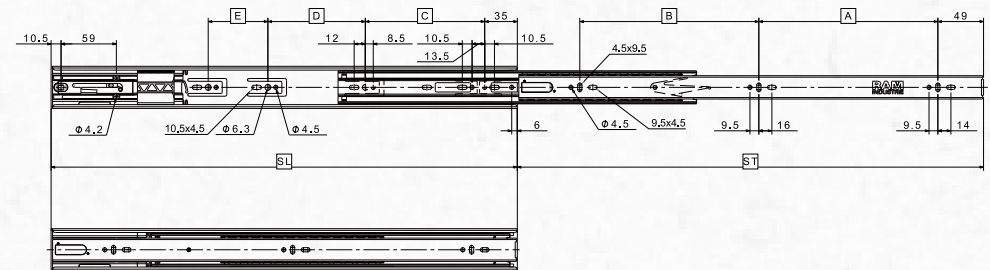
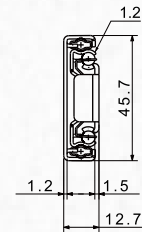

- 滑軌耐用 · 行程平穩順暢
- 正確安裝及使用狀況下壽命達50,000次
- 銅管阻尼器搭配高強度碳鋼彈簧緩衝機構
- 平邊折彎防跳珠設計 · 三段式脫鉤防呆設計
- 壓開式把手快拆機構 · 拆卸簡易快速

- Stable and running smooth with soft closing device
- 45kgs (100lb) loading by cycle testing 50,000 times
- High quality oil piston with brass alloy tube
- Quick release handle

材質：冷軋鋼板/厚度 1.2x1.2x1.5mm  
閉合長度：250mm ~ 600mm  
展開型式：三節全展型  
施工間隙：單邊12.7mm (+0.2mm -0mm)  
滑軌高度：45.7mm  
最大載重：一組45公斤(100磅)  
快拆系統：壓開式把手快拆  
表面處理：鍍鋅  
適用產品：家具櫥櫃與一般抽屜  
包裝方式：套裝15組/箱

Material: SPCC / T=1.2x1.2x1.5mm  
Length: 250mm ~ 600mm (10"~24")  
Extension: Full Extension  
Side Clearance: 12.7mm (+0.2mm -0mm)  
Height: 45.7mm (1-13/16")  
Loading rate: 45kgs (100lb)  
Finishing: Bright Zinc plating (Black option)  
application : wood furniture, cabinet  
Packing: 15 pairs/carton

產品編號. CODE.	滑軌長度 SL	展出長度 ST	A	B	C	D	E
G42250	250	195	75	75.5	-	-	-
G42300	300	280	80	121	96	-	-
G42350	350	350	128	122	72.5	64	-
G42400	400	400	128	160	128	64	-
G42450	450	450	160	160	128	104.5	-
G42500	500	500	192	192	128	104.5	64
G42550	550	550	192	224	128	104.5	96
G42600	600	600	224	256	128	104.5	128

單位：mm

# Serie 43450

標準三節側板緩衝拉籃滑軌  
(附橡皮止滑套)

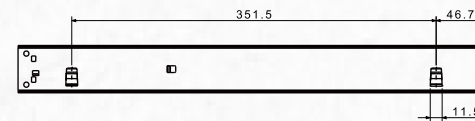
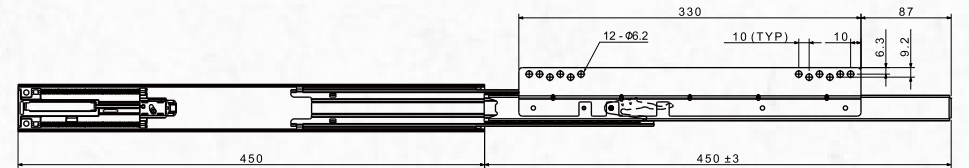
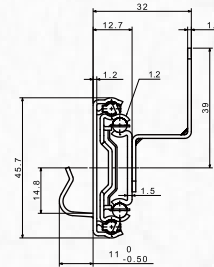

- 滑軌耐用 · 行程平穩順暢
- 正確安裝及使用狀況下壽命達50,000次
- 高穩定性靜音緩衝回歸機構
- 拉籃掛勾附橡皮止滑套 · 止滑安靜

材質：冷軋鋼板  
厚度：1.2x1.2x1.5mm / 側板1.2mm  
閉合長度：450mm (歡迎OEM尺寸)  
展開型式：三節全展型  
施工間隙：單邊32mm  
滑軌高度：45.5mm  
最大載重：一組45公斤(100磅)  
表面處理：亮白鍍鋅  
適用產品：衣櫥拉籃與櫥櫃拉籃  
包裝方式：套裝10組/箱

- Stable and running smooth with soft closing device
- 45kgs (100lb) loading by cycle testing 50,000 times
- High quality oil piston with double spring
- Baskets hook with rubber cover

Material: SPCC  
Thickness=1.2x1.2x1.5mm / Side Baskets=1.2mm  
Length: 450mm (18" OEM Welcome)  
Extension: Full Extension  
Side Clearance: 32mm  
Height: 45.5mm (1-13/16")  
Loading rate: 45kgs (100lb)  
Finishing: Bright Zinc plating  
application : wood furniture, cabinet  
Packing: 10 pairs/carton

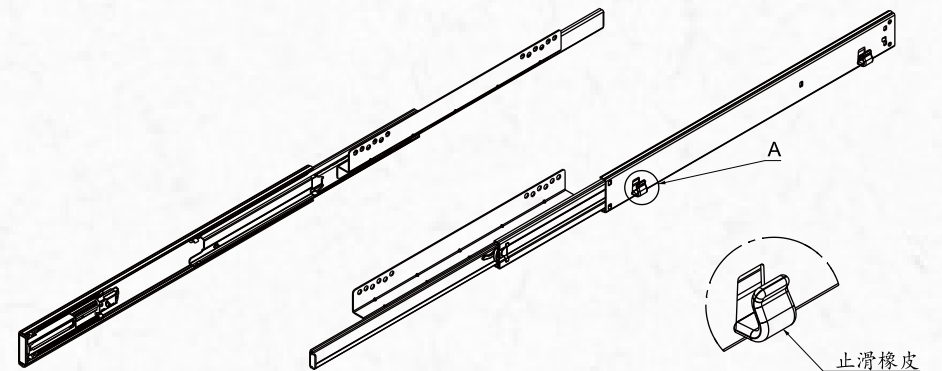

止滑橡皮





**RAM**  
**INDUSTRIE**  
中遠國際有限公司

221 新北市汐止區新台五路一段77號12樓之3

遠東世界中心B棟

電話：(02)26983188

傳真：(02)26983358

[www.ramindustrie.com.tw](http://www.ramindustrie.com.tw)

[service@ramindustrie.com.tw](mailto:service@ramindustrie.com.tw)

